

Application Circuit

Typical RF Performance bias at $V_{ds}=6.5V$, $I_{ds}=200mA$, $T_a=25\text{ }^\circ C$

Parameter	Units	Typical Data			
Test Frequency	MHz	870-960	1930-1990	2400-2600	3400-3500
Gain	dB	18	14	11	10
Input Return Loss	dB	10	10	10	10
Output Return Loss	dB	10	8	10	10
Output P1dB	dBm	28.5	28.5	28.5	28.5
Output IP3	dBm	46	46	46	46
Noise Figure	dB	3	3	4	4

Circuit Schematic:

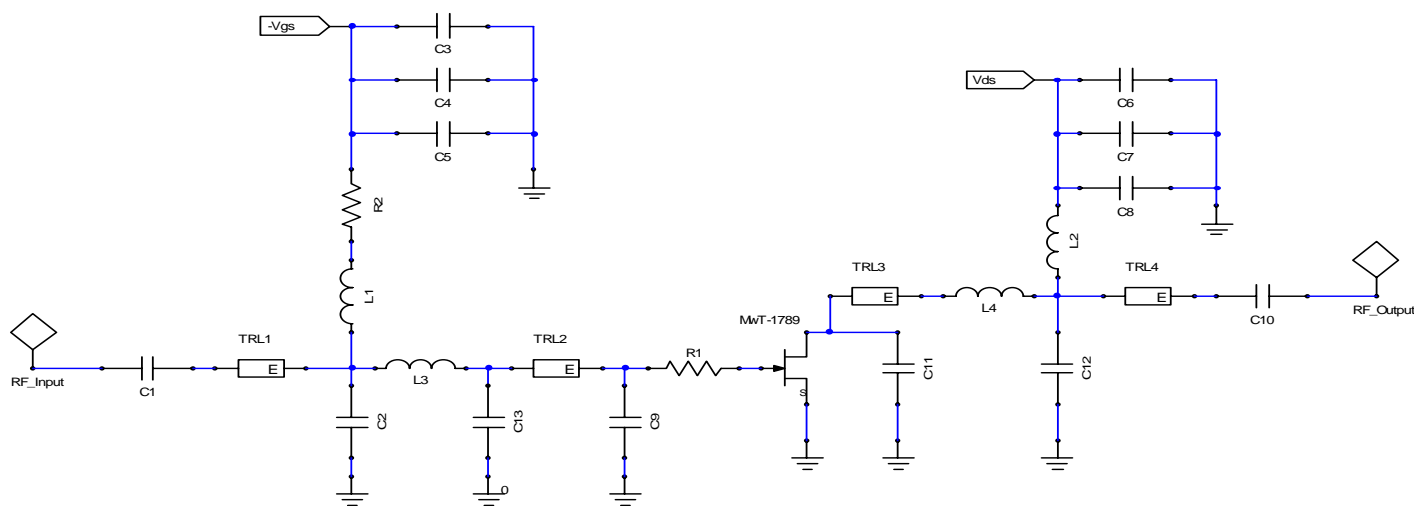

Bill of Material

Reference Designator	Value				Unit	part	Size
	0.87 – 0.96	1.93 – 1.99	2.4 – 2.6	3.4 – 3.6	GHz		
C5, C8	100	100	100	100	pF	Chip capacitor	0505
C4, C7	1000	1000	1000	1000	pF	Chip capacitor	0505
C3, C6	0.1	0.1	0.1	0.1	uF	Chip capacitor	1111
C1	100	33	0.1	22	pF	Chip capacitor	0505
C2	5.6	0.7	NI	1	pF	Chip capacitor	0505
C9	NI	2	NI	0.2	pF	Chip capacitor	0505
C10	100	33	33	22	pF	Chip capacitor	0505
C11	NI	NI	NI	0.9	pF	Chip Capacitor	0505
C12	3.3	NI	0.7	NI	pF	Chip capacitor	0505
C13	NI	NI	NI	1.2	pF	Chip capacitor	0505
L1	100	100	5.1	5.1	nH	Chip Inductor	0603
L2	100	100	100	15	nH	Chip Inductor	0603
L3	5.1	0	0	5.1	nH	Chip Inductor	0603
L4	5.1	0	0	0	nH	Chip Inductor	0603
R1	2.7	2.7	5.1	51	Ohm	Chip Resistor	0603
R2	51	51	51	0	Ohm	Chip Resistor	0603
TRL1	0	0	25	0	Deg.	50 Ohm TRL	
TRL2	0	35	15	30	Deg.	50 Ohm TRL	
TRL3	0	15	20	30	Deg.	50 Ohm TRL	
TRL4	0	20	25	35	Deg.	50 Ohm TRL	
Q	MwT-1789	MwT-1789	MwT-1789	MwT-1789		MESFET	SOT89

NI : Not Installed

RF Performance (870MHz-960MHz, $V_{ds}=6.5V$, $I_{ds}=200mA$, $T_a=25^\circ C$, unless otherwise noted)

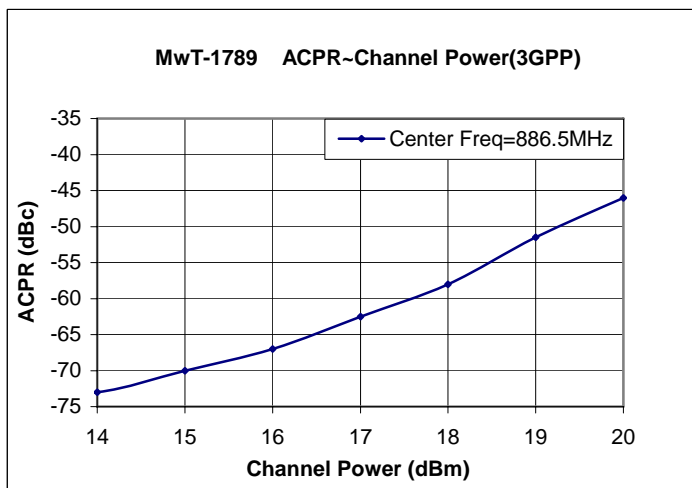
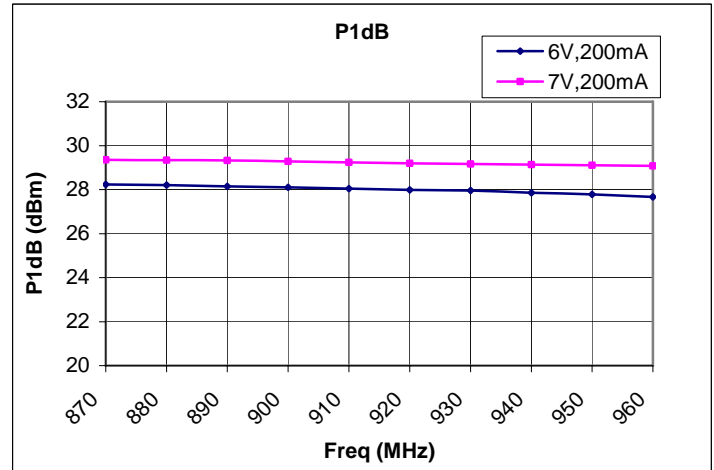
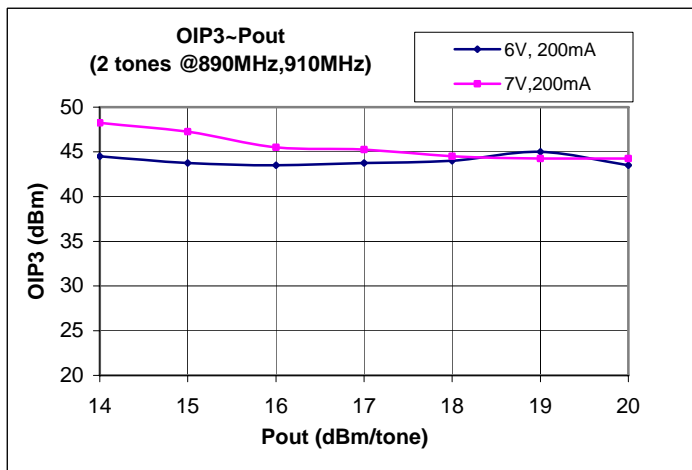
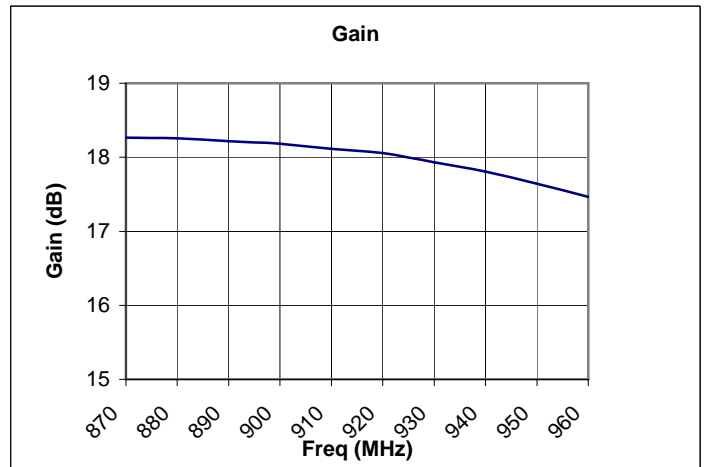
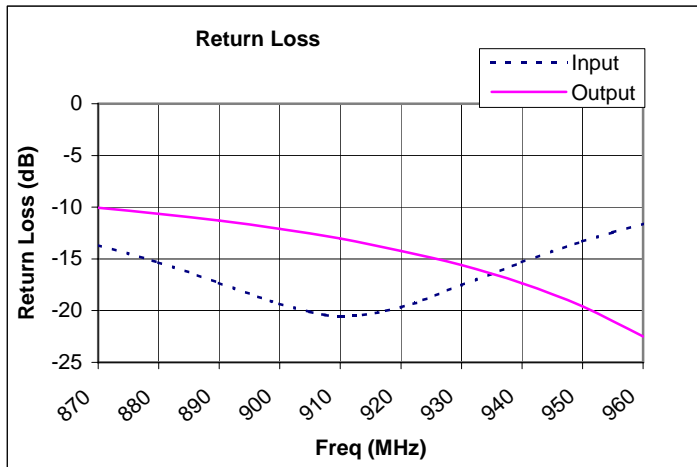

RF Performance (1.93-1.99GHz, $V_{ds}=6.5V$, $I_{ds}=200mA$, $T_a=25^\circ C$, unless otherwise noted):

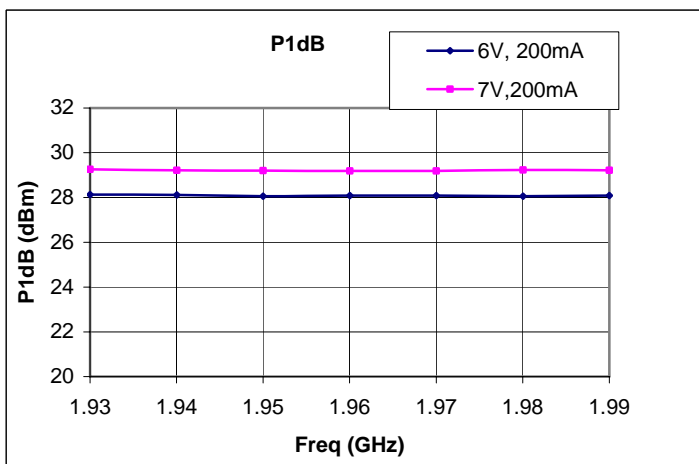
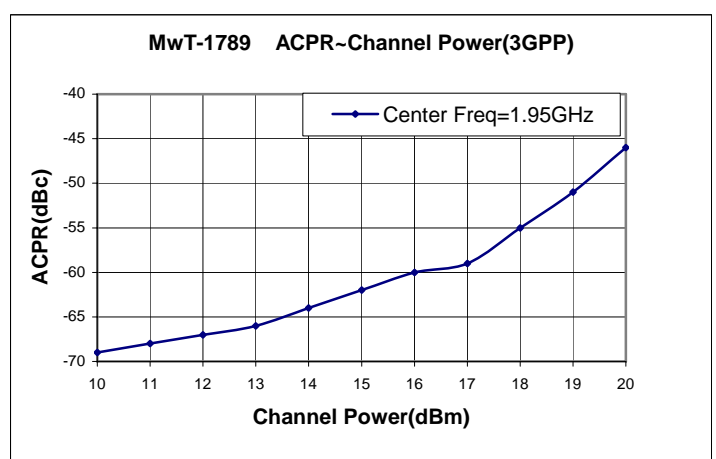
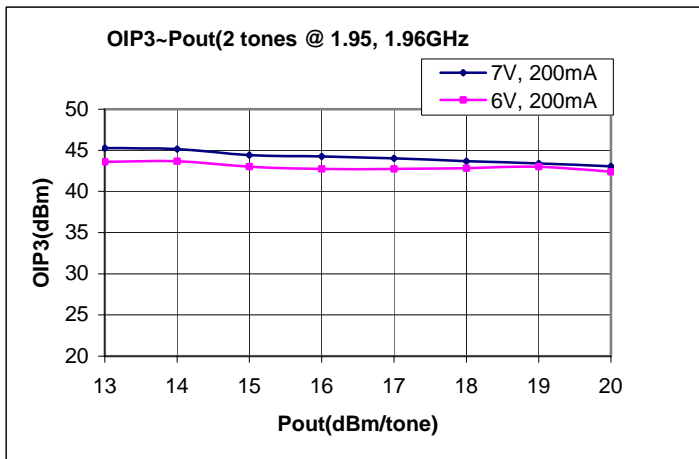
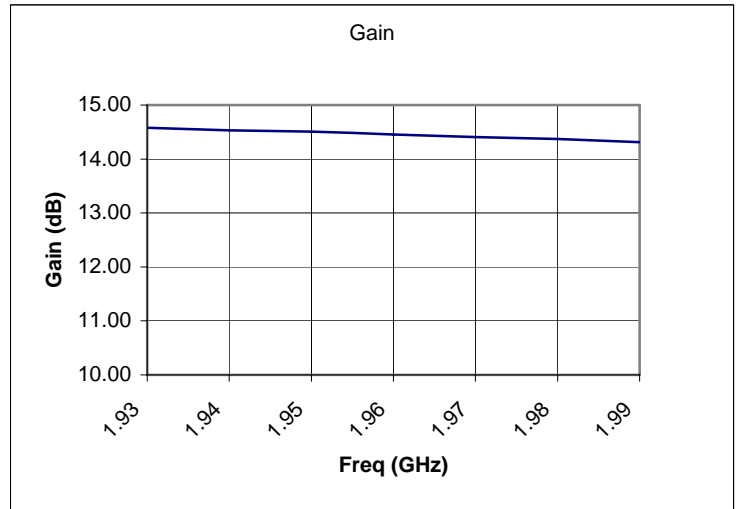
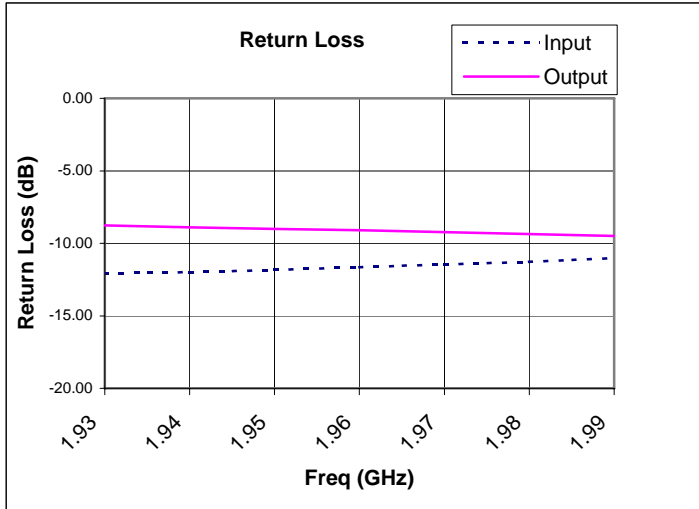

RF Performance (2.4-2.6GHz, $V_{ds}=6.5V$, $I_{ds}=200mA$, $T_a=25^\circ C$, unless otherwise noted):

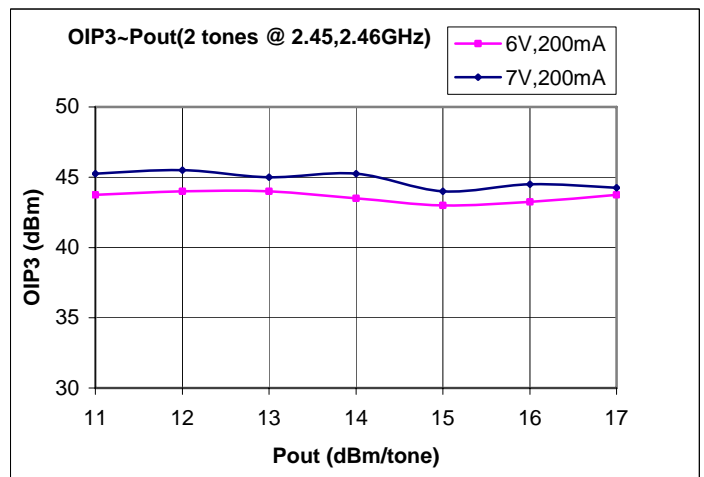
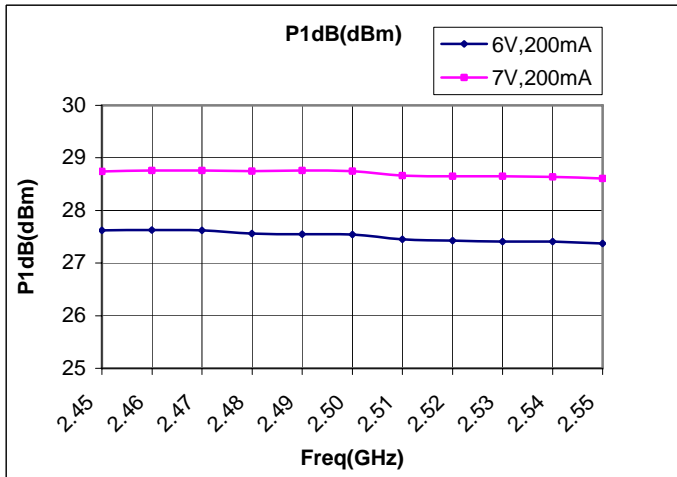
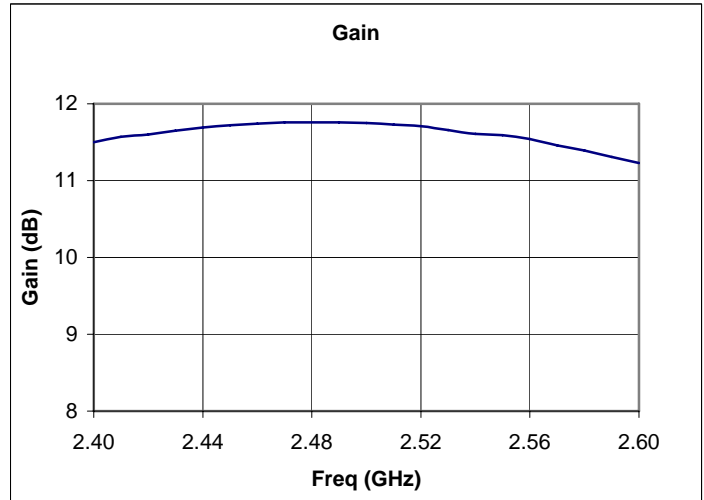
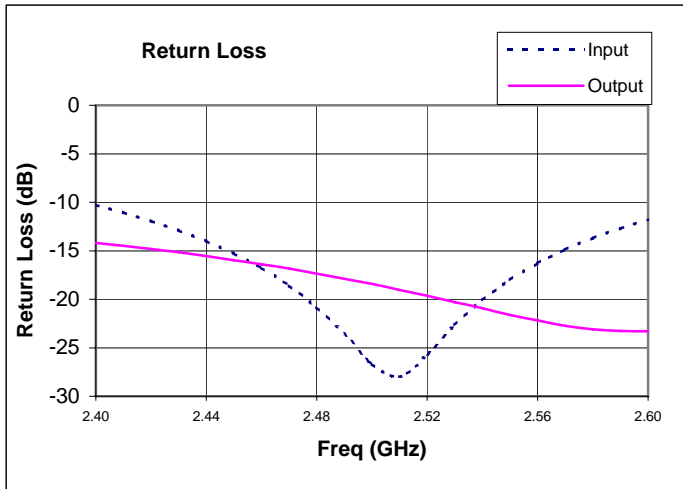

RF Performance (3.4-3.5GHz, $V_{ds}=6.5V$, $I_{ds}=200mA$, $T_a=25^\circ C$, unless otherwise noted):

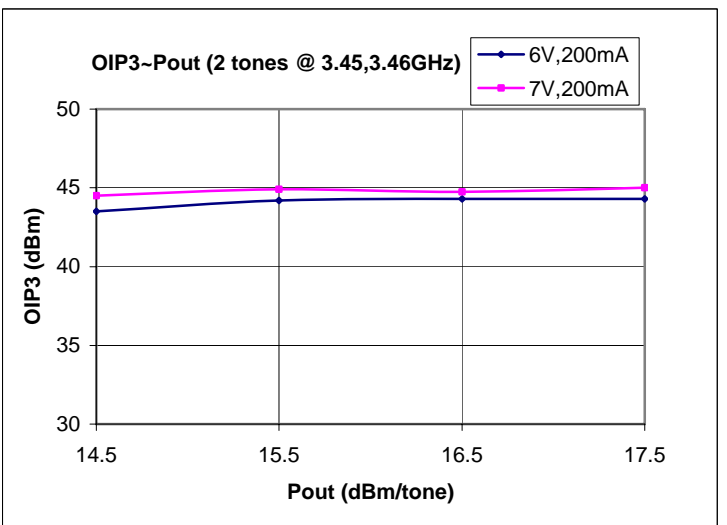
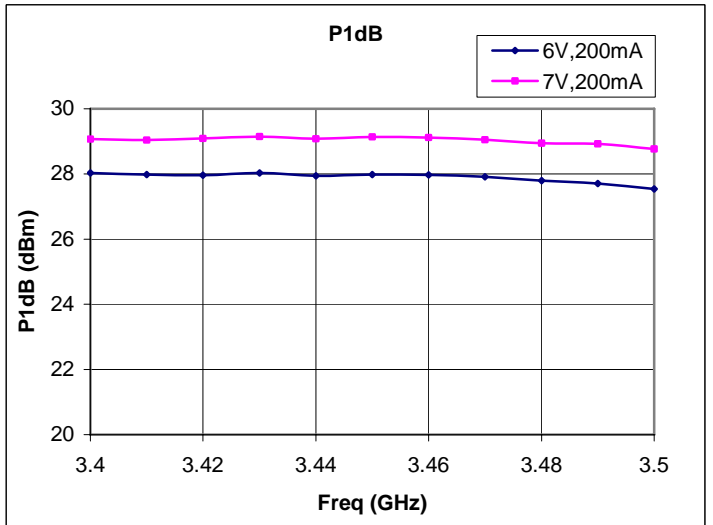
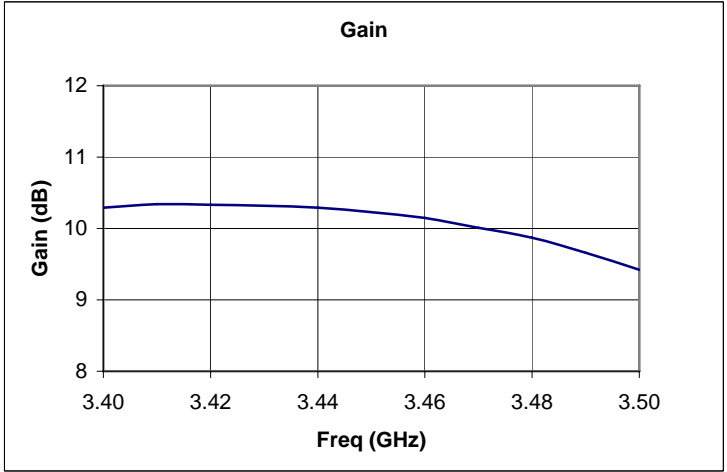
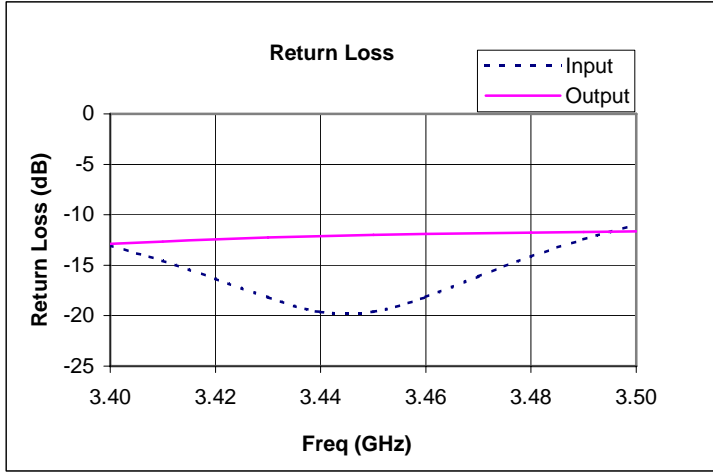

OUTLINE DRAWING

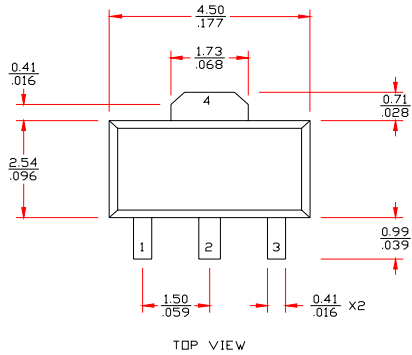

mm
inch

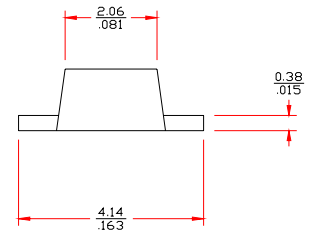
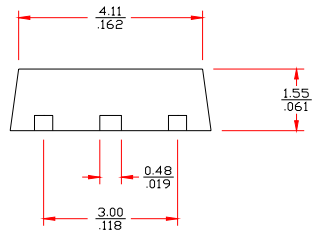

Recommended PCB Layout: (Via holes and backside metal as the heat sink, Unit is mm/inch)

