

Features:

- **Wideband:** 50 to 1000 MHz
- **Output Power:** 24 dBm P1dB
- **Excellent Linearity:** 42 dBm OIP3 & 74 dBm OIP2
- **Gain:** 16.5 dB
- **Excellent Gain Flatness:** +/- 0.25 dB up to 860 MHz
- **Bias Condition:** +5V , 264 mA
- **Single +5V Supply With On-Chip Active-Bias For Ease Of Operation & external bias adjust capability**
- **Dual Matched Amplifiers in single package for High IP2 Push-Pull configuration**
- **Lead Free RoHS Compliant Surface-Mount SOIC-8 Package with Gnd Slug**

Functional Diagram

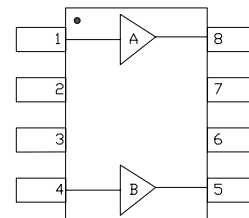

Function	Pin No.
AMP A Input	1
AMP A Output	8
AMP B Input	4
AMP B Output	5
Ground	2,3,6,7, Backside Slug

Applications:

- CATV Head End Equipment
- CATV Line Amplifiers
- Cable Modem
- Optical Driver application
- Instrumentation
- General Purpose Gain Block

Description:

The MHA-051023D-88 is a broadband cascadable Dual Matched MMIC amplifier utilizing high-reliability InGaP/GaAs HBT technology. Packaged in low cost SOIC-8 lead-free Green Package, the Dual Amplifiers are ideally suited for High IP2 Push-Pull CATV distribution, Cable Modem and laser diode driver applications. It has excellent linearity, very good return loss and gain flatness over a broad frequency range. The third order intercept point performance is excellent, typically 18 dB above P-1dB. The dual amplifiers deliver High IP2 in excess of 72 dBm in Push-Pull configuration using low-cost widely available transformers. It has on-chip bias circuit to provide bias stability and ease of use. External bias adjust capability is also available.



MHA-051023D-88

50 - 1000 MHz High IP2 Push-Pull CATV Amplifier

Preliminary Data Sheet
Feb 2009

Electrical Specifications: @ $V_{cc}=+5.0V$, $I_{cc}=264mA$, $T_a=25\text{ }^\circ\text{C}$ $Z_0=75\text{ ohm}$ ⁽¹⁾

Parameter	Units	Typical	
Frequency Range	MHz	50-1000	
Gain	dB	16.5	
Gain Flatness	+/-dB	0.25	50 MHz to 860 MHz
Input Return Loss	dB	14	
Output Return Loss	dB	20	
Output P-1dB	dBm	23.7	50 MHz
		24.0	250 MHz
		24.2	500 MHz
		23.9	860 MHz
		23.8	1000 MHz
Output IP3 @ 8 dBm/tone, 1 MHz separation	dBm	42	50 MHz
		43	250 MHz
		42.5	500 MHz
		41	860 MHz
		40.5	1000 MHz
Output IP2 @ 8 dBm/tone	dBm	76	499/553 MHz, Meas @ 54 MHz
		75	811/865 MHz, Meas @ 54 MHz
		76	439/853 MHz, Meas @ 414 MHz
		85	427/433 MHz, Meas @ 860 MHz
		72	327/533 MHz, Meas @ 860 MHz
		68	227/633 MHz, Meas @ 860 MHz
Noise Figure	dB	5.3	
Operating Bias Conditions: V_{cc} I_{cc}	V mA	+ 5 264	Combined Pair

(1) All Data is measured on Evaluation PCB in 75-ohm Push-Pull configuration optimized for wideband (50-1000 MHz) performance referenced to RF connectors

Absolute Maximum Ratings:

SYMBOL	PARAMETERS	UNITS	ABSOLUTE MAXIMUM
V_{cc}	Collector Voltage	V	5.5
I_{cc}	Collector Current	mA	300
P_{diss}	DC Power Dissipation	W	TBD
$P_{in\ max}$	RF Input Power	dBm	TBD
T_{oper}	Operating Case/Lead Temperature Range	$^\circ\text{C}$	- 40 to + 85
T_{ch}	Channel Temperature	$^\circ\text{C}$	150
T_{stg}	Storage Temperature	$^\circ\text{C}$	-60 to +150

*Operation of this device above any one of these parameters may cause permanent damage.

Typical RF Performance: $V_{cc}=5V$, $I_{cc}=264mA$, $T_a=25\text{ }^\circ C$ $Z_0 = 75\text{ Ohm}$, Push-Pull Evaluation PCB

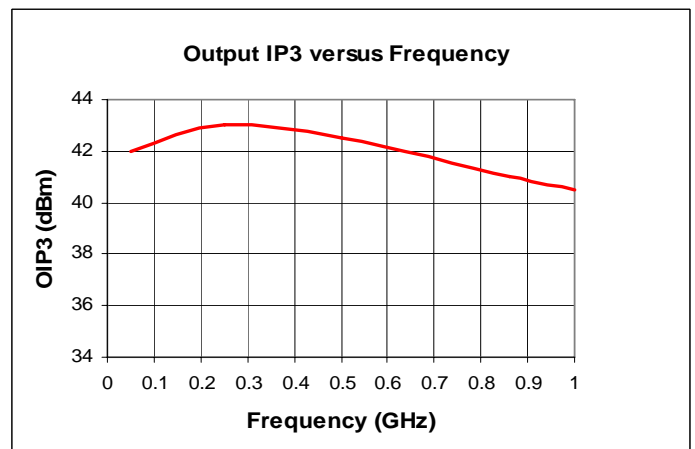
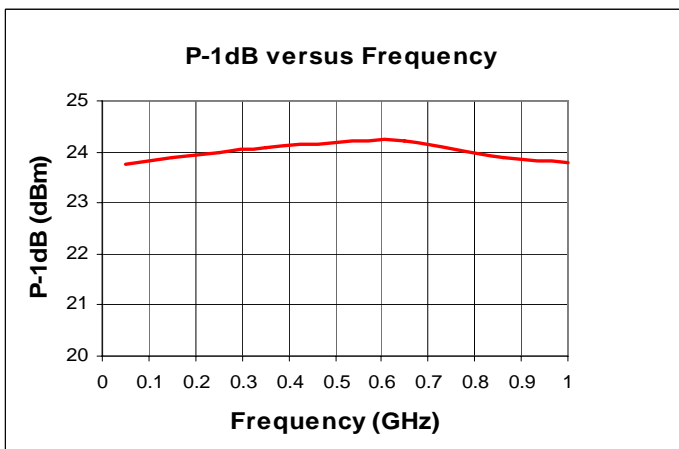
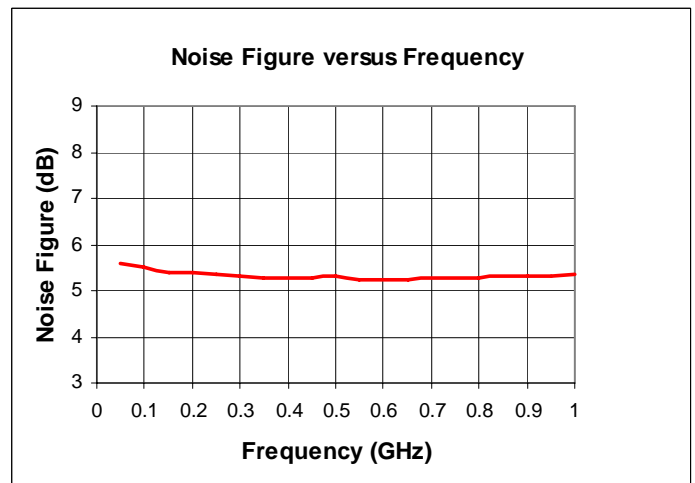
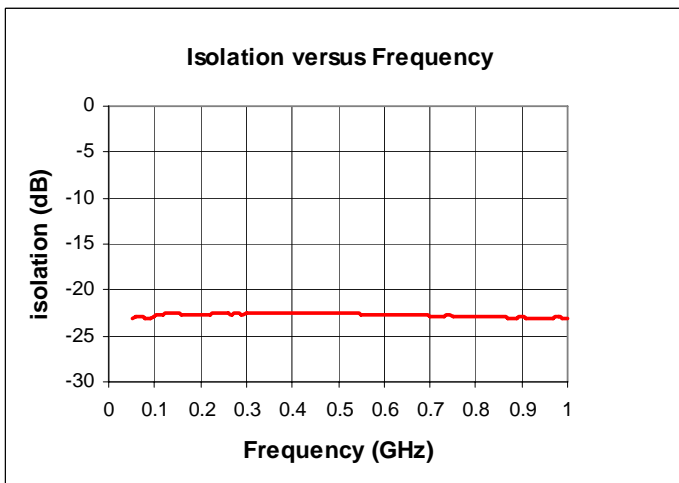
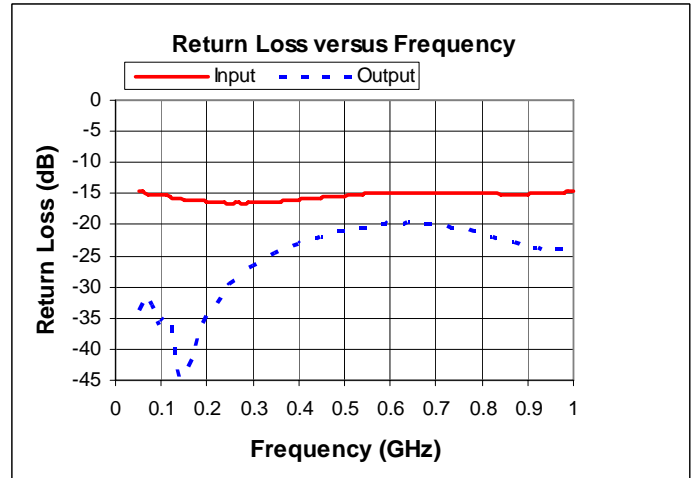
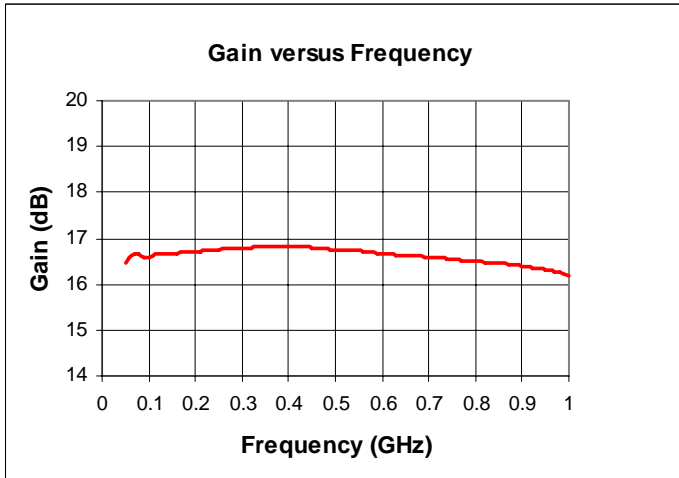

75- ohm Push-Pull Application Circuit Schematic

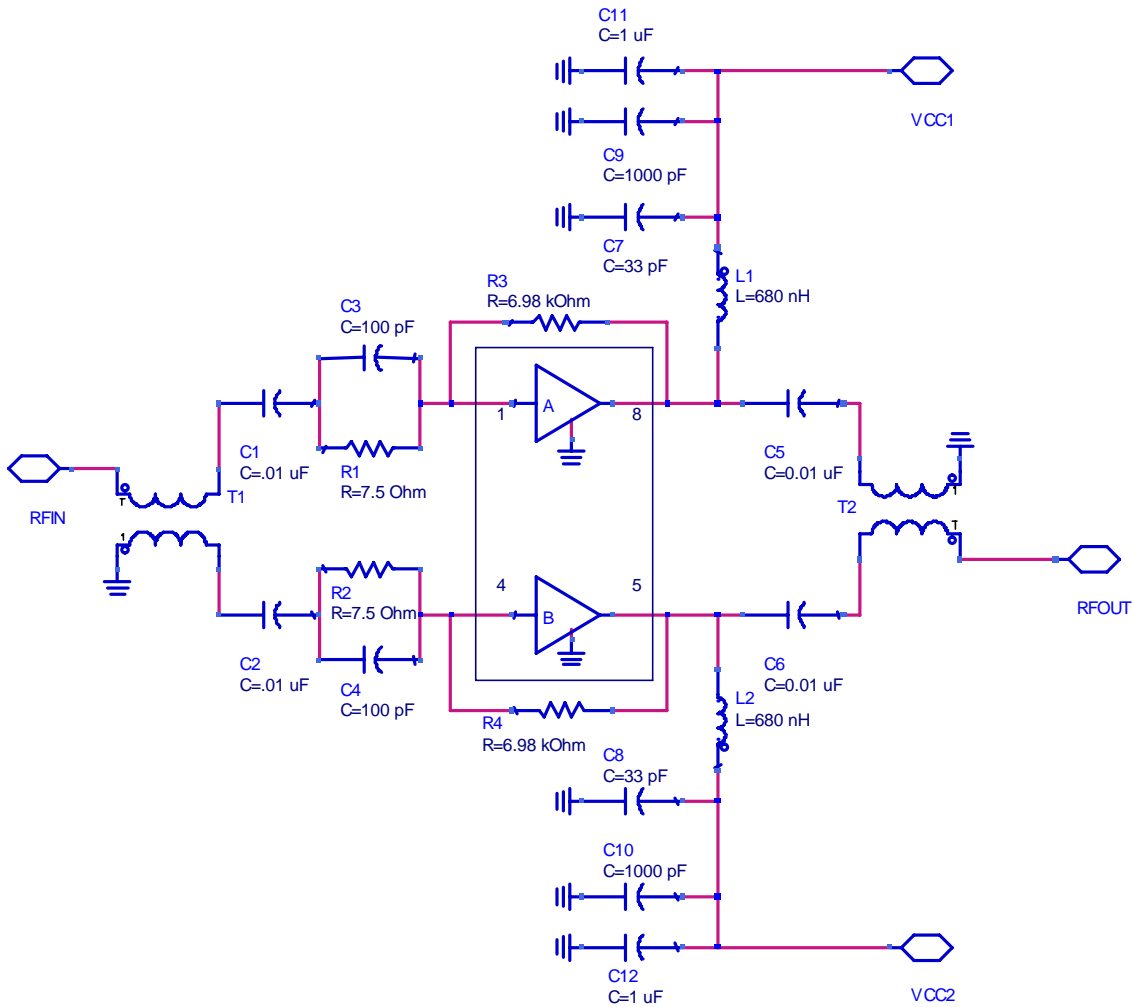

NOTES:

- 1) R3, R4 are optimized for setting the desired bias current
- 2) R1, C3 and R2, C4 are designed to compensate for transformer insertion loss roll-off and optimize overall gain flatness.
- 3) Bias is applied from each side using RF choke at each amplifier RF output
- 4) DC blocking capacitors are required at amplifier input & output.
- 5) The package backside slug must be soldered to PCB gnd vias for RF/DC grounding and optimum thermal impedance. See PCB layout for details.

75-ohm Push-Pull Amplifier Evaluation Board Layout & BOM

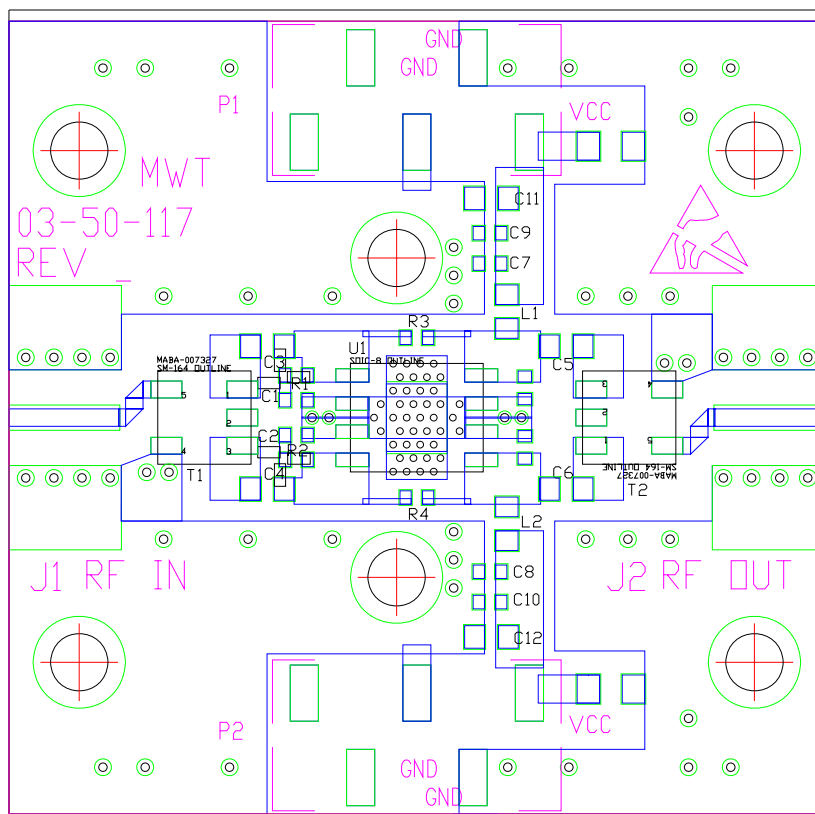

NOTES:

- 1) PCB is 4-layer stack. Material: VT-461 Er=3.66 Top Layer to 1st Gnd Layer Thickness: 28 mil with total 1 oz plated Cu. Total Board Thickness: 65 mil.
- 2) RF Input/Output interface is designed for 75-ohm BNC End-launch connectors.
- 3) Evaluation Board measured with transformer MABA-007327. Alternatively other commercial transformers like MABACT0059, ETC1-1-13 and ADTL1-18-75 should give equivalent performance.

PCB 03-50-117 Application Circuit BOM MHA-051023D-88

Ref #	Part No.	Value	Vendor
R1,R2	RK73B1ETTP7R5J (0402)	7.5 ohm	KOA
R3,R4	RK73H1ETTP6981F (0402)	6.98K Ohm	KOA
C1,C2	0402YC103KAT2A	0.01uF	AVX
C3,C4	04025A101JAT2A	100pF	AVX
C7,C8	04025A330JAT2A	33 pF	AVX
C9,C10	04025C102KAT2A	1000 pF	AVX
C5,C6	06035C103KAT2A	0.01 uF	AVX
C11,C12	0603YD105KAT2A	1 uF	AVX
L1,L2	0603LS-681XJLB	680 nH	COILCRAFT
U1	MHA-051023D-88	SOIC-8 PKG	MWT
T1,T2	MABA-007327-CT1A40	BALUN	MACOM
P1,P2	TSM-105-01-S-SV	DC STRIP	SAMTEC
PCB	03-50-117 REV_		MWT
J1,J2	112622 BNC END LAUNCH	75 ohm BNC JACK	AMPHENOL

Mechanical Information:

Package is RoHS-compliant lead free Green Package: 150mil Body SOIC-8 with ground slug

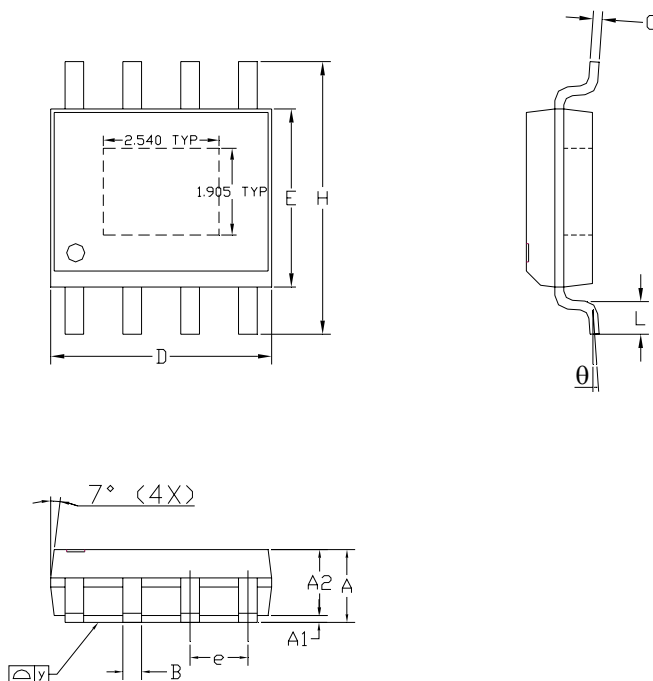

NOTE

1. PACKAGE BODY SIZES EXCLUDE MOLD FLASH AND GATE BURRS
2. DIMENSION L IS MEASURED IN GAGE PLANE
3. TOLERANCE 0.10 mm UNLESS OTHERWISE SPECIFIED
4. CONTROLLING DIMENSION IS MILLIMETER. CONVERTED INCH DIMENSIONS ARE NOT NECESSARILY EXACT.
5. FOLLOWED FROM JEDEC MS-012
6. THERMAL SLUG DIMENSION : 75mils X 100mils

SYMBOLS	DIMENSIONS IN MILLIMETERS			DIMENSIONS IN INCHES		
	MIN	NOM	MAX	MIN	NOM	MAX
A	1.45	1.50	1.55	0.057	0.059	0.061
A1	0.00	---	0.15	0.000	---	0.006
A2	---	1.45	---	---	0.057	---
B	0.33	---	0.51	0.013	---	0.020
C	0.19	---	0.25	0.007	---	0.010
D	4.80	---	5.00	0.189	---	0.197
E	3.80	---	4.00	0.150	---	0.157
e	---	1.27	---	---	0.050	---
H	5.80	---	6.20	0.228	---	0.244
L	0.40	---	1.27	0.016	---	0.050
y	---	---	0.10	---	---	0.004
θ	0°	---	8°	0°	---	8°