

Features:

- **Wide Frequency Range:** 1.0 to 12 GHz
- **Excellent NF :** 1.6 dB @ 6.0 GHz
- **High Gain:** 17 dB @ 6 GHz
- **P-1dB:** 16 dBm @ 6 GHz
- **OIP3:** 27 dBm @ 6 GHz
- **Bias Condition:** VDD = 5 V and IDD = 55 mA
- **50-Ohm On-chip Matching**
- **Unconditionally Stable:** 50 MHz to 20 GHz
- **6x6 mm, 12 Lead Hermetic Ceramic SMT Package**
- **Also Available in Low Cost Non-Hermetic SMT Packages**

Applications:

- **Satellite Communications**
- **Space and Hi-Rel Applications**
- **EW Systems**
- **Telemetry**
- **Test Instrumentation**
- **Microwave Point-to-Point Radios**
- **Wide-band Communication Systems**
- **Commercial Wireless System**

Description:

The MLA-01122B-H6 is a packaged fully-matched broadband Low-Noise MMIC amplifier utilizing high-reliability low-noise GaAsAl/InGaAs PHEMT technology. This MMIC is suited for Satellite Communications, Microwave radios, Instrumentation, Wideband Systems and also many commercial wireless applications where low-noise figure with high-gain is desirable. It has excellent gain (17 dB) and Noise Figure (1.6 dB, mid-band) over a broad frequency range. Typical P-1dB is 16 dBm with OIP3 of +27dBm @ 6 GHz. Its on-chip bias circuit, choke, and DC blocking provide bias stability and ease of use. Available in 6x6mm, 12 Lead Ceramic SMT Hermetic Package, and other low cost non-hermetic SMT packages.

Functional Diagram

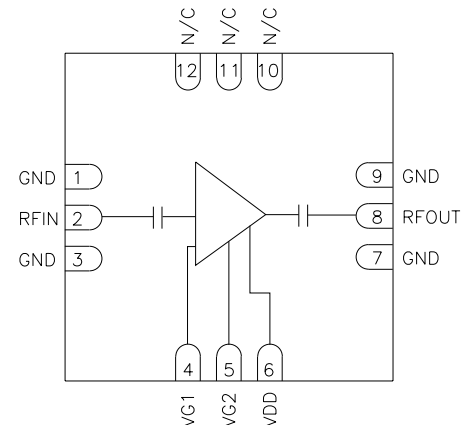

Electrical Specifications: $V_{DD}=+5.0V, V_{G1}=+0.14V, V_{G2}=+2V, I_{DD}=55mA, T_a=25\text{ }^\circ\text{C } Z_0=50\text{ ohm}^{(1)}$

Parameter	Units	Typical	Test Conditions
Frequency Range	GHz	1 - 12	
Noise Figure	dB	1.5 1.6 2.0	2 GHz 6 GHz 12 GHz
Gain	dB	17 18	1 – 8 GHz 10 – 12 GHz
Gain Flatness	+/-dB	0.7 1.0	1 – 8 GHz 1 – 12 GHz
Input Return Loss	dB	14 12 12	2 GHz 6 GHz 12 GHz
Output Return Loss	dB	11	
Output P-1dB	dBm	17.5 16.0 15.5 14.0	2 GHz 6 GHz 10 GHz 12 GHz
Output IP3 @ 0 dBm/tone, 1 MHz separation	dBm	31 27 26	2 GHz 6 GHz 12 GHz
Operating Bias Conditions: V_{DD} I_{DD}	V mA	+ 5 55	$V_{G1}= +0.14\text{ V typ.}$ $V_{G2}= + 2\text{ V, typ.}^{(1)}$
Stability Factor K		> 1	0.05 to 20 GHz

(1) All Data is measured on Evaluation Board, with V_{G2} bias derived from V_{DD} bias using resistive voltage divider as shown in Evaluation Board Schematic & Layout. V_{G1} is used to set the desired bias current. Typical V_{G1} ranges from +0.1 to +0.2 V.



MLA-01122B-H6

1 - 12 GHz Low Noise MMIC Amplifier in Hermetic Package

May, 2011

Absolute Maximum Ratings:

SYMBOL	PARAMETERS	UNITS	ABSOLUTE MAXIMUM
VDD	Drain Voltage	V	7
IDD	Drain Current	mA	75
Pdiss	DC Power Dissipation	W	0.4
Pin max	RF Input Power	dBm	13
Toper	Operating Case/Lead Temperature Range	°C	- 40 to + 85
Tch	Channel Temperature	°C	150
Tstg	Storage Temperature	°C	-60 to +150

*Operation of this device above any one of these parameters may cause permanent damage.

Typical RF Performance: $V_{DD}=+5.0V$, $V_{G1}=+0.14V$, $V_{G2}=+2V$, $I_{DD}=55mA$, $T_a=25\text{ }^\circ\text{C}$ $Z_0=50\text{ ohm}$ ⁽¹⁾

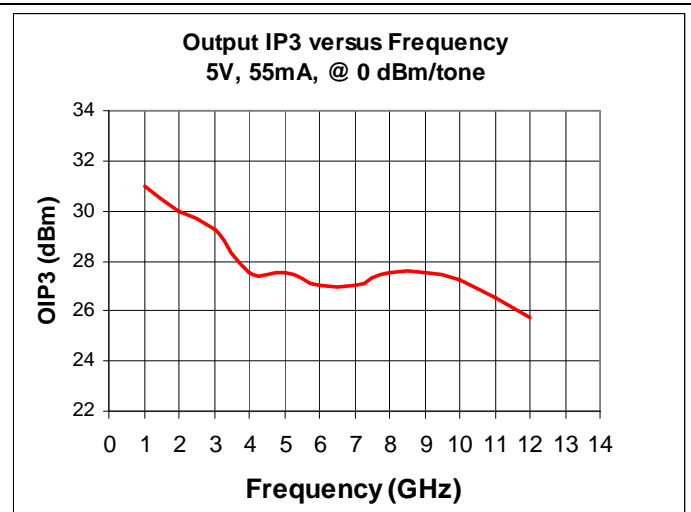
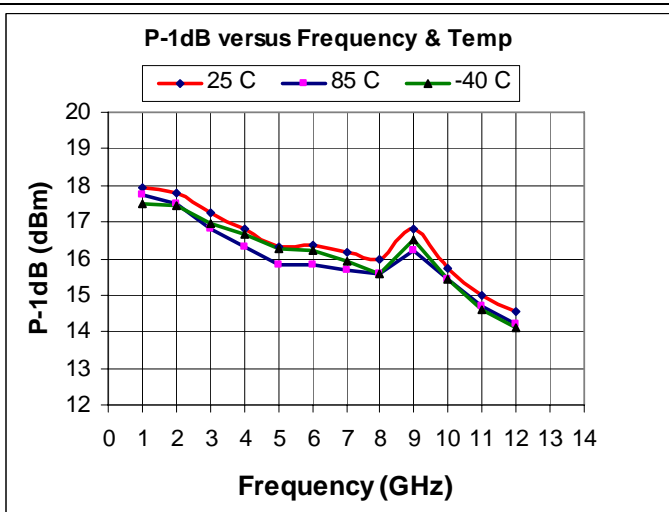
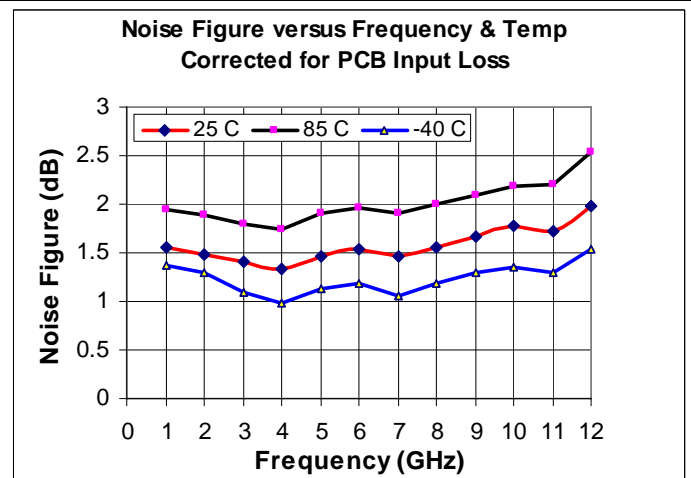
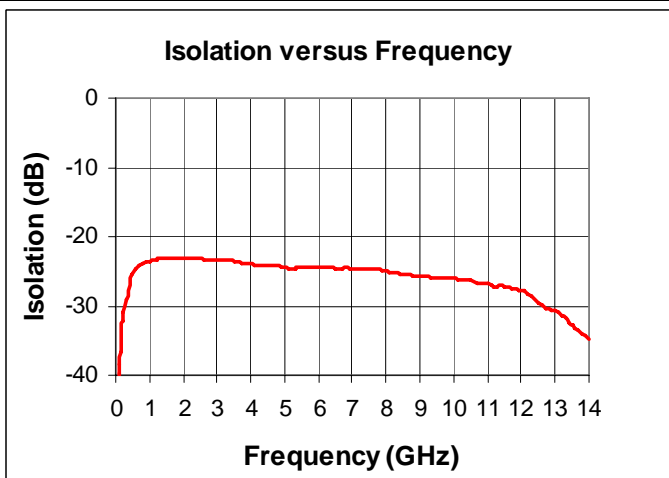
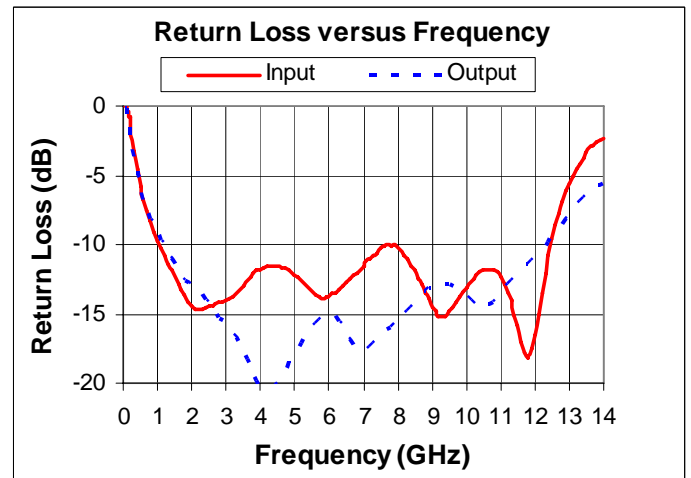
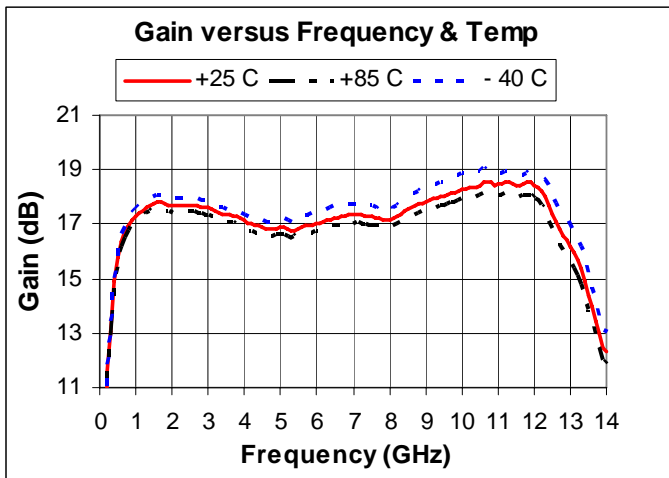

Application Circuit Schematic

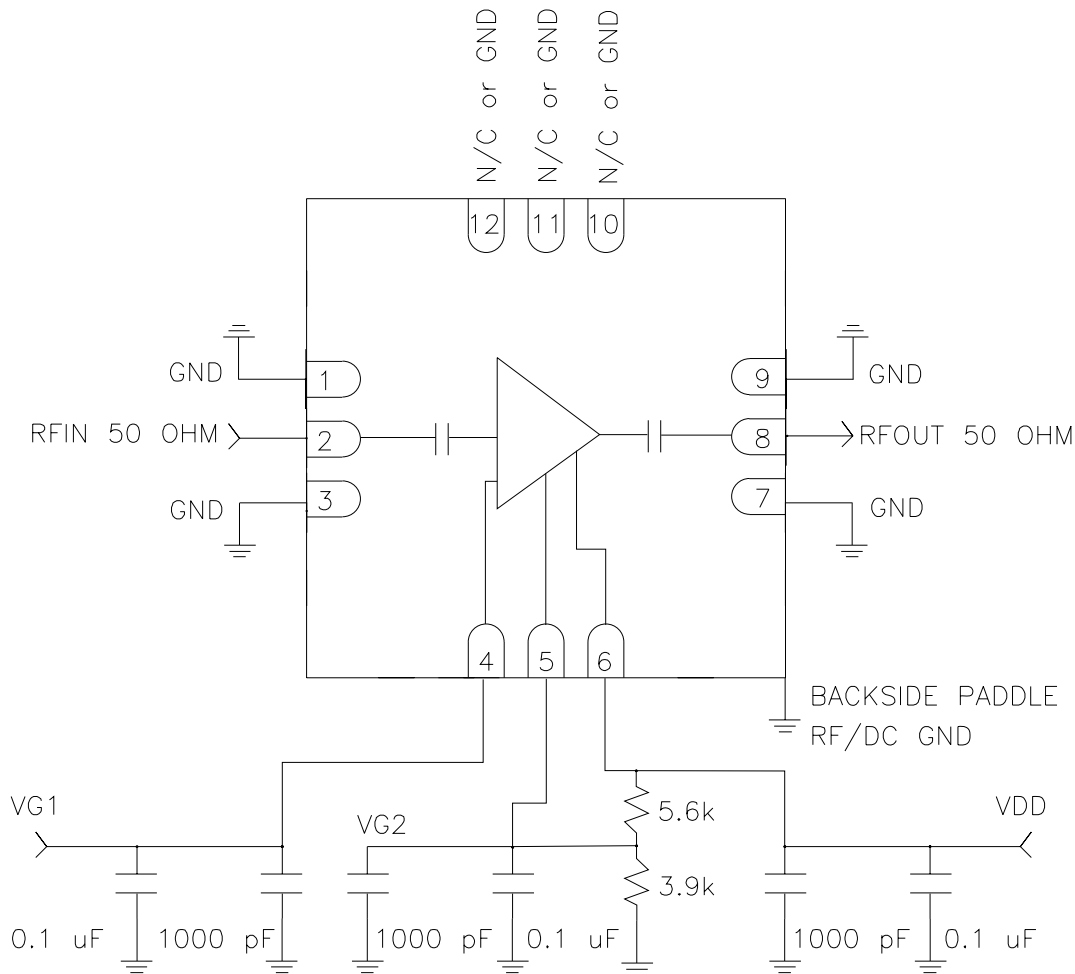

Notes:

- 1) Package Backside is RF/DC GND and must be well grounded through PCB vias.
- 2) External DC bypass capacitors must be placed as close to package as possible.

Evaluation Board Layout & BOM

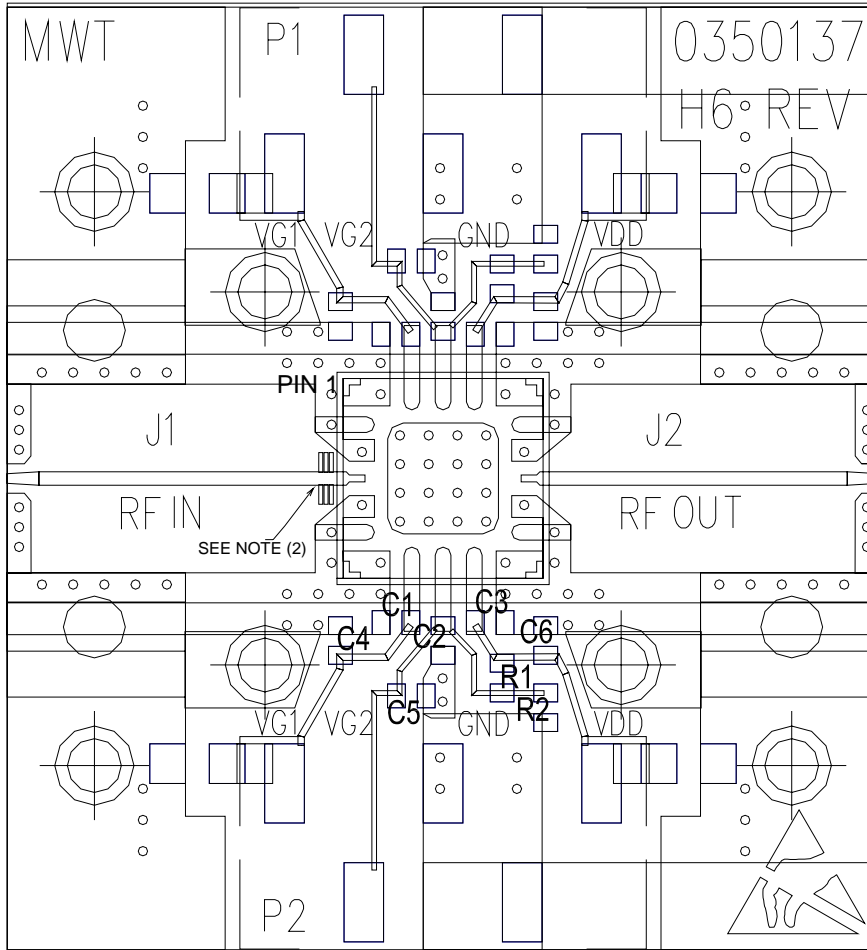

PARTS LIST

C1,C2,C3: 04025C102KAT2A 1000pF	AVX
C4,C5,C6: 0402ZD104KAT2A 0.1uF	AVX
R1: RK73B1ETTP562J (0402) 5.6k	AVX
R2: RK73B1ETTP392J (0402) 3.9k	AVX
P2: TSM-105-01-S-SV	SAMTEC
J1, J2: 292-06A-5 RF CONNECTOR	SOUTHWEST MICROWAVE
PCB: 03-50-137	MwT

NOTES:

- 1) VIAS BELOW THE PACKAGE ARE SOLID FILLED VIAS.
- 2) INPUT TUNING STUBS REQUIRED FOR BEST BROADBAND RETURN LOSS. ATTACH 3 RIBBON STUBS(W=5 MILS, L=25 MILS EACH) ON EACH SIDE OF 50 OHM LINE NEAR RF INPUT TO PACKAGE AS SHOWN.

Mechanical Information:

6X6 mm, 12 Lead Ceramic Hermetic Package Outline Drawing
Dimensions are in mm

Pin 1

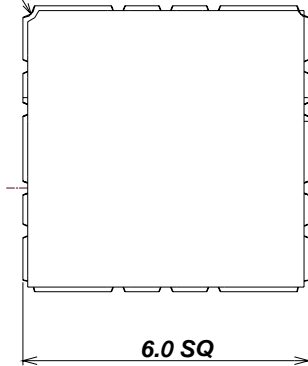

Topside

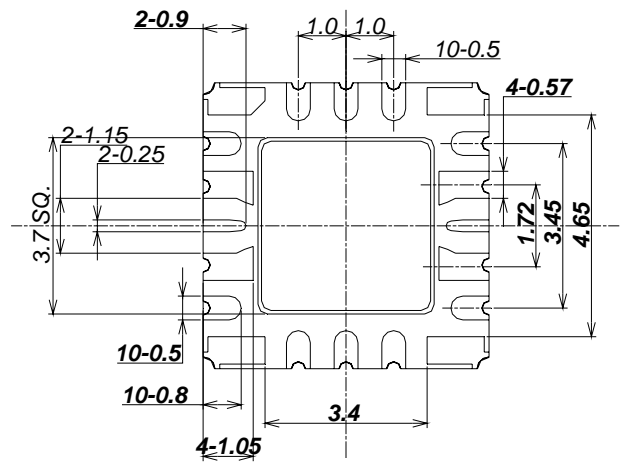

Backside (Leadless SMT)

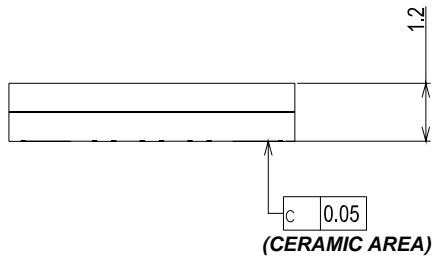

ALL DIMENSIONS IN MM
X = +/- 0.1
XX = +/- 0.05