

### Features

- +45 dBm Typical IP3
- 14 dB Typical Gain
- +29 dBm Typical Output Power
- Single Positive Bias
- Surface Mount Package or Half Flange Package

The MPS213011 is a modular amplifier designed to meet the ultralinear transmitter output requirements of worldwide PDC systems. The amplifier exhibits an extremely high IP3 (+45dBm) relative to the DC power consumed (3 W). The device is self contained with all matching and bias circuitry included. Typical applications for this device include driver stages for single channel and multicarrier feed forward linear amplifiers used in North American PCS and DCS-1800 (GSM) systems. It is also useful for a lower power micro-cell amplifier output stage where multicarrier configurations require excellent multitone intermodulation performance.

### Specifications

- Electrical at 25°C, V<sub>dd</sub>= 7.5 V, Z<sub>o</sub>= 50 Ω

Symbol	Parameter	Min.	Typical	Max	Unit
Freq	Frequency Range	1700		2100	MHz
SSG	Small Signal Gain	13	14		dB
P1dB	P out at 1 dB Compression		+29.0		dBm
IP3	Third-order Intercept	+42.0	+45.0		dBm
VSWR	Input VSWR		1.5:1/2.2:1		
ΔGOF	Gain Variation over Freq.		+/- 0.25	+/- 0.50	dB
ΔGOT	Gain Variation over Temp.		-.01		dB/°C
I <sub>dd</sub>	DC Current		350	420	mA

Gain vs. Frequency

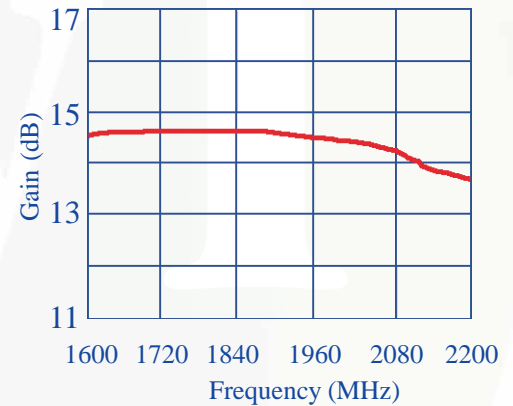

Output Power at P1dB

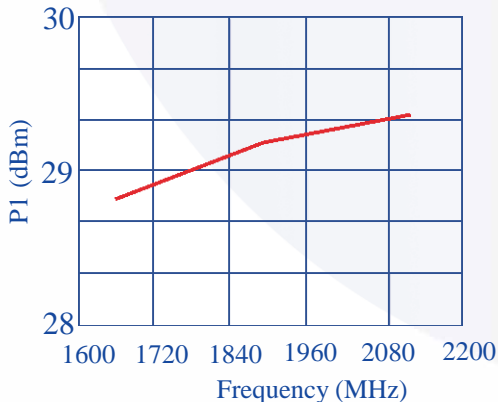

### Absolute Maximum Ratings

Maximum Bias Voltage	8.0 V
Maximum Continuous RF Input Power	950 mW
Maximum Peak Input Power	1400mW
Maximum Case Operating Temperature	+85°C
Maximum Storage Temperature	-65°C to +150°C

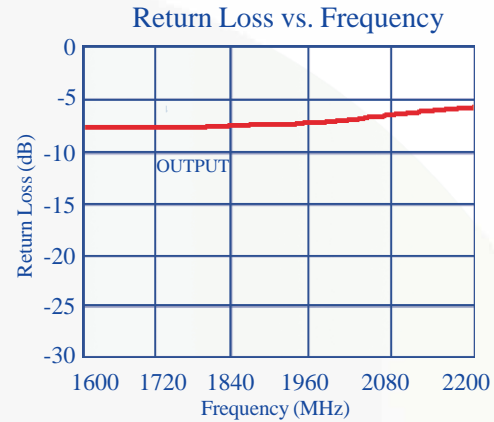
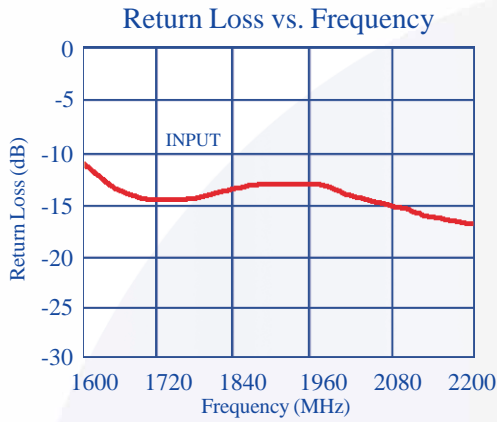

### Outline Diagrams

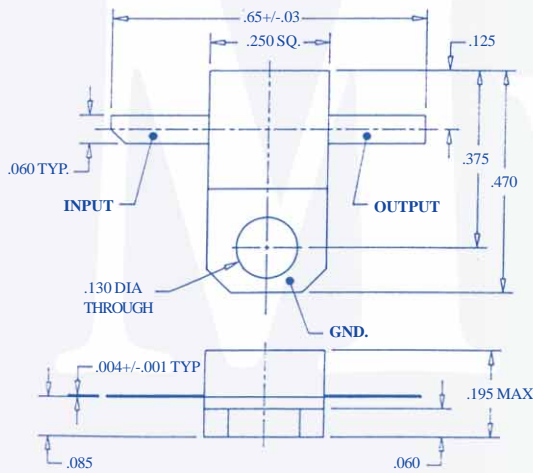

Package 85

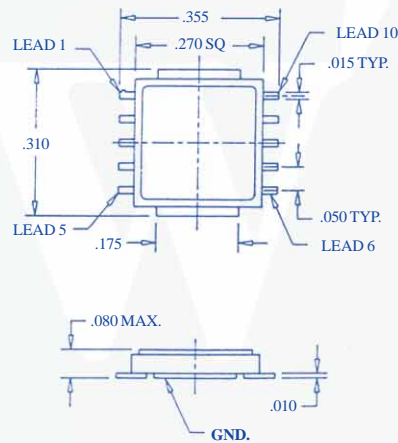

Package 86 (HERMETIC)

Pin	Connection
1	N/C
2	N/C
3	RF Input
4	N/C
5	N/C
6	N/C
7	N/C
8	RF Output, Vdd
9	N/C
10	N/C
Case	Ground

### Application Circuit

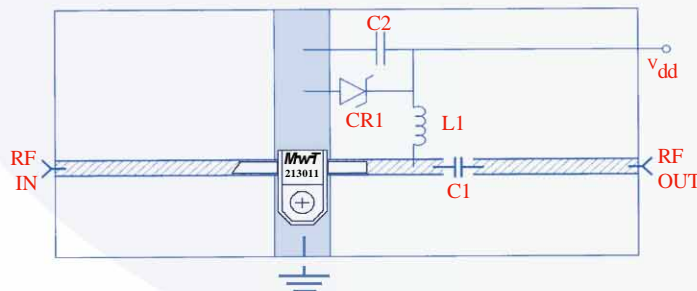

- C1 100 pF Chip Capacitor
- C2 .22 pF Capacitor
- L1 160 nH Printer or Wound Coil
- CR1 8.0 V Zener Diode
- 50 Ω Microstrip Line