



Linear Amplifier 2400 to 2700 MHz

- IP_3 : 45 dBm
- P_{1dB} : 28.5 dBm
- Gain: 13 dB



Model #: **MPS-253011-02**

Features

- Leadless Chip Carrier
- +45 dBm IP_3
- +28.5 dBm P_{1dB}
- 13 dB Gain
- Single Positive Bias
- Interchangeable with MPS-253011-82 both electrically and mechanically
- Systems applications for this device are: MMDS, ISM, and WLL

Description

The **MPS-253011-02** is a modular amplifier designed to meet the ultralinear transmitter output requirements of worldwide ISM band systems and wireless cable distribution. The amplifier exhibits an extremely high IP_3 (+45 dBm). The device is self contained with all matching and bias circuitry included. Typical applications for this device include output stages for North American and European 2.4 GHz ISM band and MMDS band systems. It is useful for direct sequence and or frequency hopped spread spectrum systems where excellent output linearity is required. Typical systems include wireless LAN, industrial telemetry, and wireless cable links.

Absolute Maximum Ratings

Bias Voltage	8.0V
Continuous RF Input Power	950 mW
Peak Input Power	1400 mW
Case Operating Temperature	+85°C
Storage Temperature	-65°C to +125°C

Electrical at 25°C, V_{dd}= 7.5 V, Z_o= 50 Ω

Symbol	Parameter	Min.	Typ.	Max.	Unit
Freq	Frequency Range	2400		2700	MHz
SSG	Small Signal Gain	12.0	13.0		dB
P _{1dB}	P out at 1 dB Compression		+28.5		dBm
IP3	Third-order Intercept*	+42.0	+45.0		dBm
VSWR	Input / Output		2.0:1 / 2.0:1		
ΔGOF	Gain Variation over Freq.		±0.25	±0.5	dB
ΔGOT	Gain Variation over Temp.		-.012		dB/°C
I _{dd}	DC Current		380	450	mA

*Two tone tests at P out = +13 dBm/tone, centered at 2400 MHz with 20 MHz separation

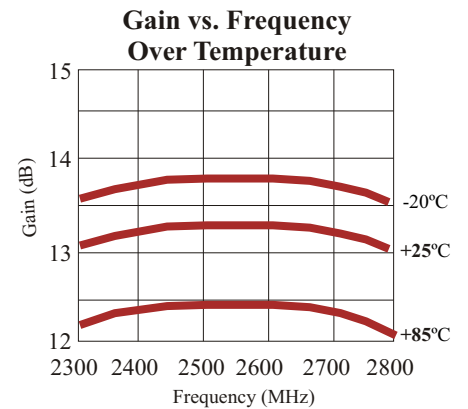
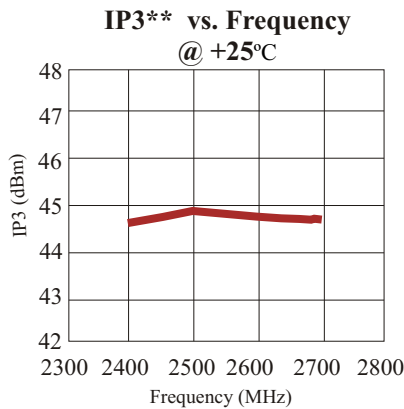
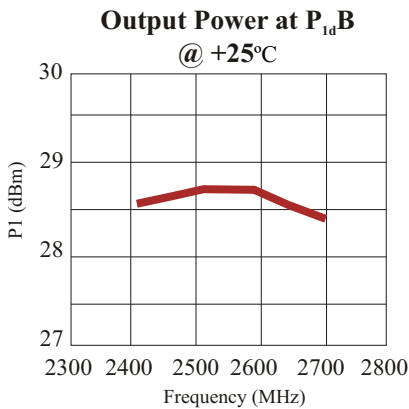

**Two tone test, P out = +13 dBm/tone; with 20 MHz separation

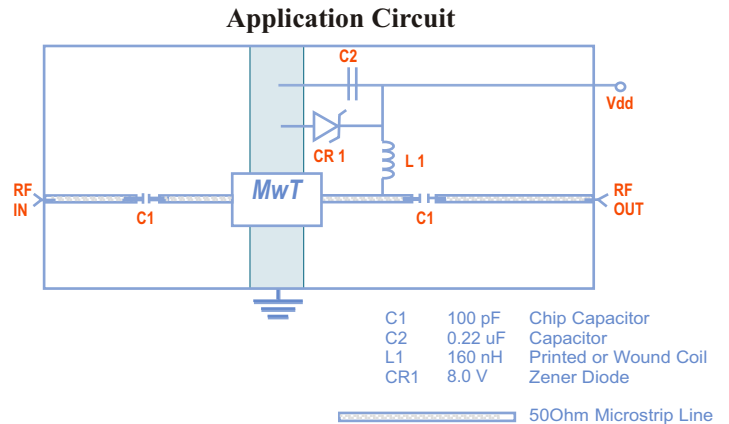
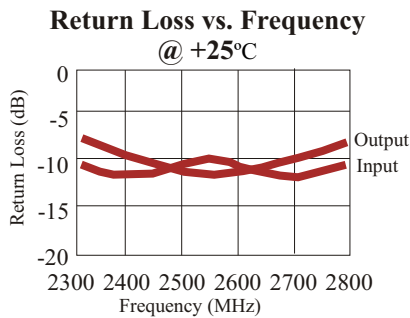

MPS-253011-02 Outline Drawing

Packaging is interchangeable with MPS-253011-82

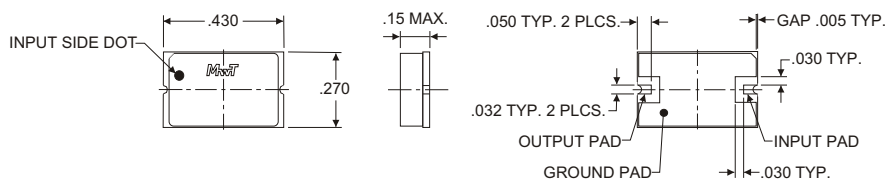

MicroWave Technology, Inc., 4268 Solar Way, Fremont, CA 94538

Tel: (510) 651-6700 Fax: (510) 651-2208 Web Site: www.mwtinc.com E-mail: info@mwtinc.com