

MwT-2

26 GHz High Power GaAs FET

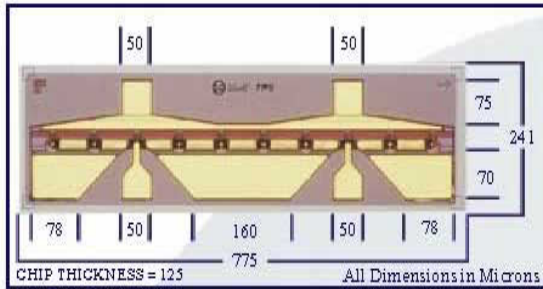

DOWNLOAD ADDITIONAL DATA WWW.MWTINC.COM



FEATURES

- 9 dB SMALL SIGNAL GAIN AT 12 GHz
- +24.5 dBm OUTPUT POWER AT 12 GHz
- 0.3 MICRON REFRACTORY METAL/GOLD GATE
- 630 MICRON GATE WIDTH
- CHOICE OF CHIP AND THREE PACKAGE TYPES

DESCRIPTION

The MwT-2 is a GaAs MESFET device whose nominal quarter-micron gate length and 630 micron gate width make it ideally suited to applications requiring high-gain in the 500 MHz to 26 GHz frequency range with power outputs ranging from 100 to 200 milli-watts. The straight geometry of the MwT-2 makes it equally effective for either wideband (e.g. 6 to 18 GHz) or narrow-band applications. The chip is produced using MwT's reliable metal system and devices from each wafer are screened to insure reliability. All chips are passivated using MwT's patented "Diamond-Like Carbon" process for increased durability. Designers can use MwT's unique BIN selection feature to choose devices from narrow Idss ranges, insuring consistent circuit operation.

DC SPECIFICATIONS AT Ta = 25°C

SYMBOL	PARAM. & CONDITIONS	UNITS	MIN	TYP	MAX
IDSS	Saturated Drain Current Vds= 4.0 V VGS= 0.0 V	mA	60		240
Gm	Transconductance Vds= 4.0 V VGS= 0.0 V	mS	75	100	
Vp	Pinch-off Voltage Vds= 3.0 V IDS= 4.0 mA	V		-2.0	-5.0
BVGSO	Gate-to-Source Breakdown Volt. Igs= -0.4 mA	V	-6.0	-12.0	
BVGDO	Gate-to-Drain Breakdown Volt. Igd= -0.4 mA	V	-8.0	-12.0	
Rth	Thermal Resistance MwT-2 Chip, MwT-270,273 MwT-271	°C/W		80	180*
				80*	80*

*Overall Rth depends on case mounting.

RF SPECIFICATIONS AT Ta = 25°C

SYMBOL	PARAMETERS AND CONDITIONS	FREQ	UNITS	MIN	TYP
P1dB	Output Power at 1 dB Compression VDS= 6.0 V IDS= 0.6 x IDSS	12 GHz 18 GHz	dBm	23.0	24.5 24.0
SSG	Small Signal Gain VDS= 6.0 V IDS= 0.6 x IDSS	12 GHz 18 GHz	dB	8.0	9.0 6.0
PAE	Power Added Efficiency VDS= 6.0 V IDS= 0.6 x IDSS	12 GHz	%	30	35
IDSS	Recommended IDSS Range for Optimum P1dB		mA		160- 220

DEVICE EQUIVALENT CIRCUIT MODEL

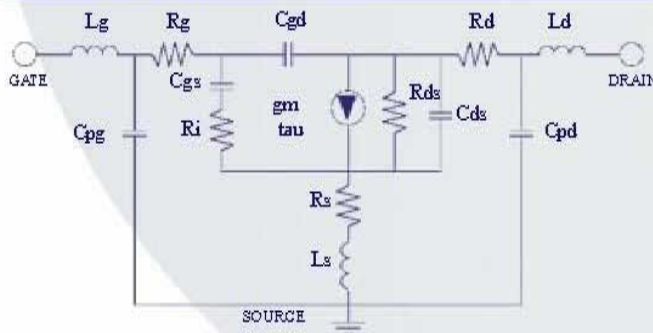

PARAMETER VALUE

PARAMETER	VALUE
Source Resistance	Rs 0.73 Ω
Source Inductance	Ls 0.03 nH
Drain-Source Resistance	Rds 200 Ω
Drain-Source Capacitance	Cds 0.007 pF
Drain Resistance	Rd 0.84 Ω
Drain Pad Capacitance	Cpd 0.142 pF
Drain Inductance	Ld 0.113 nH
Gate Bond Wire Inductance	Lg 0.18 nH
Gate Pad Capacitance	Cpg 0.1 pF
Gate Resistance	Rg 0.5 Ω
Gate-Source Capacitance	Cgs 0.67 pF
Channel Resistance	Ri 1.0 Ω
Gate-Drain Capacitance	Cgd 0.05 pF
Transconductance	gm 83.0 mS
Transit Time	tau 3.5 psec

ORDERING INFORMATION

Chip	MwT-2
Package 70	MwT-270
Package 71	MwT-271
Package 73	MwT-273

NOTE:

For Package information, please see supplementary application note from our website at www.mwtinc.com. When placing order or inquiring, please specify BIN range, wafer no., if known, and screening level required.

4268 Solar Way, Fremont, CA 94538 | Email sales@mwtinc.com | Phone (510) 651-6700 | Fax (510) 952-4000

All rights reserved. MicroWave Technology, Inc. All specifications subject to change without notice.

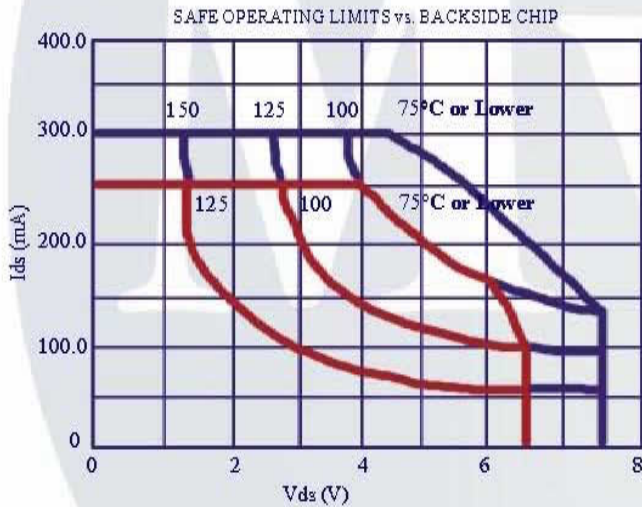
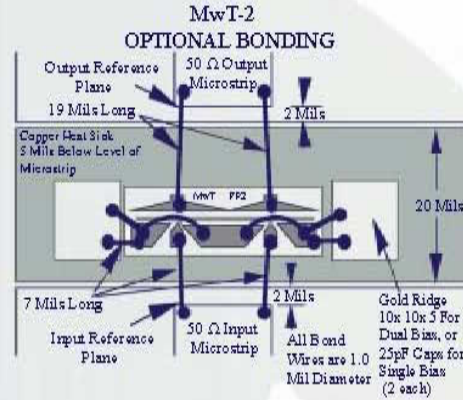
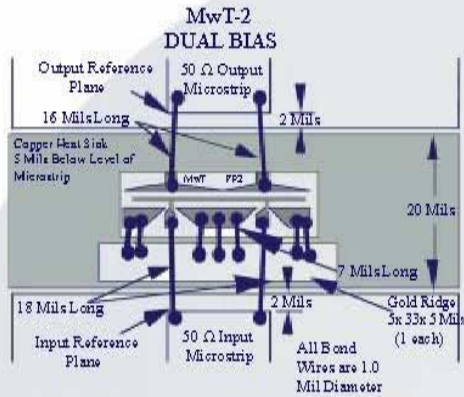

Absolute Maximum Continuous Maximum

MAXIMUM RATINGS AT $T_a = 25^\circ\text{C}$

SYMBOL	PARAMETER	UNITS	CONT MAX ¹	ABSOLUTE MAX ²
VDS	Drain to Source Voltage	V	See Safe Operating Limits	
Tch	Channel Temperature	°C	+150	+175
Tst	Storage Temperature	°C	-65 to +150	+175
Pin	R.F Input Power	mW	250	380

NOTES: 1. Exceeding any one of these limits in continuous operation may reduce the mean-time-to-failure below the design goals.
 2. Exceeding any one of these limits may cause permanent damage.

Bin	A	B	C	D
Idss Range	60-90	90-120	120-180	180-210

BIN ACCURACY STATEMENT

When placing order or inquiring, please specify BIN range, wafer no., if known, and screening level required.

4268 Solar Way, Fremont, CA 94538 | Email sales@mwtinc.com | Phone (510) 651-6700 | Fax (510) 952-4000

All rights reserved. MicroWave Technology, Inc. All specifications subject to change without notice.